



SUCTION SCANNER SELF CLEANING FILTER SERIES SCR

SCRO



SCRL



MAIN TECHNICAL CHARACTERISTICS:

- Continuous flow including during washing phase
- Filtration degree from 2000 to 25 μm on polyester mesh/ AISI316
- Maximum flow rate 1000 m^3/h with a single filter
- Minimum quantity of water at discharge

APPLICATIONS

- Pre-filtration in UF systems
- Evaporation towers
- Spray nozzle protection
- Heat exchangers
- Irrigation
- Sea water

Ver.2022 Rev00

OPERATION

WORK

Water enters the filter through the IN inlet and goes through the filtering cylinder (4) from the inside to the outside. This will retain all non-deformable suspended solids that are the same size or bigger than the filtration degree installed. Filtered water leaves through the outlet pipe (OUT).

REGENERATION

The continuous settling of suspended solids inside the filtering cylinder (4) obstructs the passage of water which results in a pressure difference (ΔP). At a preset value of ΔP (range 0.3 ÷ 1 Bar) an automatic cycle will start to clean the filter cylinder (4). This operation begins with a signal that opens the discharge valve (3) and creates communication between the suction nozzles (1) with the outside environment. At the same time, the electric motor (5) creates a rotating motion which enables the nozzles to inspect the filtering surface. Dirt is ejected through the discharge valve (3). The cleaning cycle lasts approximately 15 seconds.

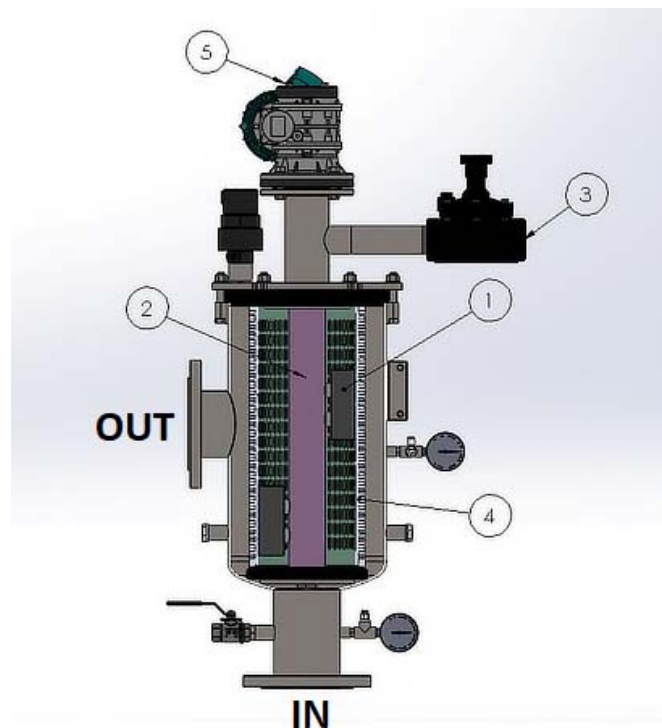

FILTER ELEMENT AND CLEANING SYSTEM

FILTRATION PHASE

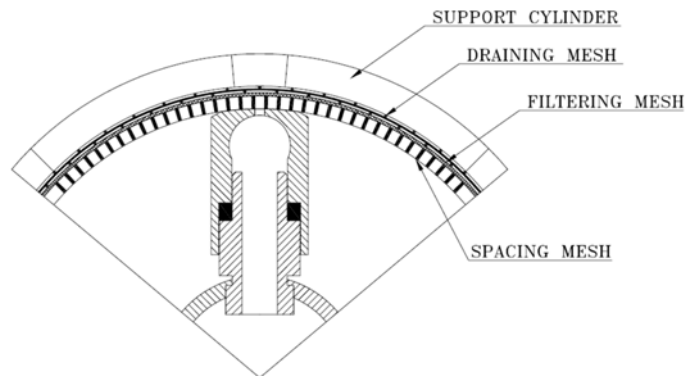

WASHING PHASE

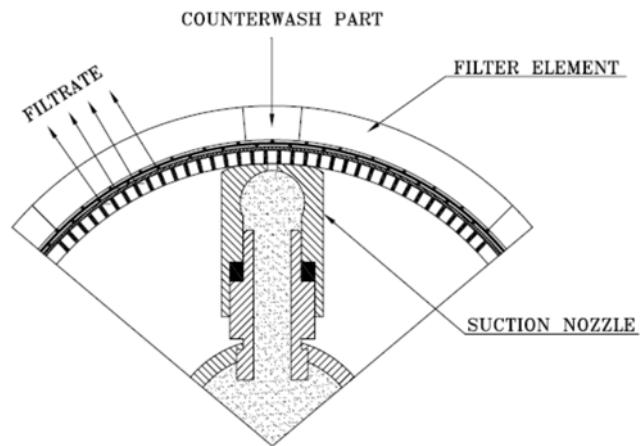

PICTURE OF FILTER INTERIOR



ELFI srl

Via Scodoncello 41/E 43044 Collecchio (PR)

CONTROL

A switchboard controls the washing phases. The signal that starts the cleaning cycle is given by a differential pressure switch or by time. The switchboard gives an "alarm" signal in case of problems in the washing system. These signals can be sent to a pre-existing control centre. The washing phase can also be controlled manually. The solenoid controlling the valve is pneumatic.



DIMENSIONS AND TECHNICAL DATA SCR L

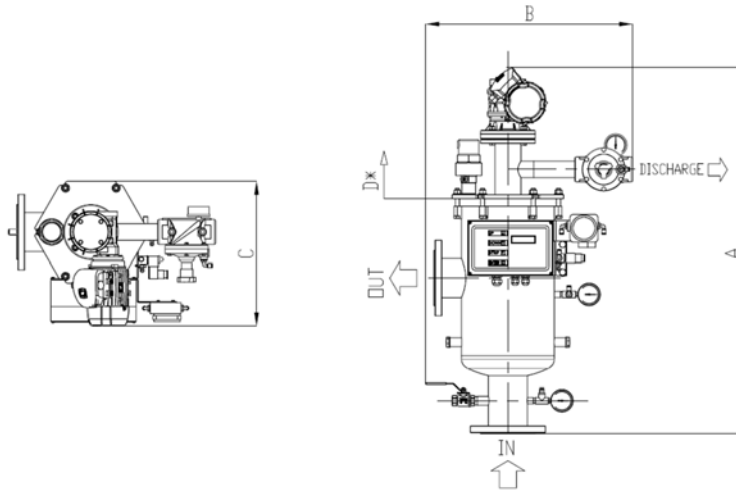

MODEL	SCR L 10	SCR L 15	SCR L 30	SCR L 45	SCR L 60	SCR L 75	SCR L 90	SCR L 130
Filtering area (cm ²)	1000	1500	3000	4500	6000	7500	9000	13000
Connections- In/Out	2"-3"	2-3" DN100	3" DN100D N150	DN100 DN150	DN100 DN150 DN200	DN150D N200DN 250	DN150 DN200 DN250	DN200D N250DN 350
Exhaust connections	1" F	1" F	1"1/2 F	1"1/2 F	1"1/2 F	1"1/2 F	1"1/2 F	2" F
Draining connections	1/2" F	1/2" F	1/2" F	1/2" F	1/2" F	1/2" F	1" F	1" F
1 Bar washing flow rate with mesh from 500 to 25 micron - m ³ /h	2	3	4	7	9	9	9	15
Wash duration - Sec.	15	15	15	15	15	15	15	15
Min-max pressure - Bar	0,5-10	0,5-10	0,5-10	0,5-10	0,5-10	0,5-10	0,5-10	0,5-10
Max Temperature - °C	40	40	40	40	40	40	40	40
Power supply - Volt	400 50/60 Hz	400 50/60 Hz	400 50/60 Hz	400 50/60 Hz	400 50/60 Hz	400 50/60 Hz	400 50/60 Hz	400 50/60 Hz
Power required - Watt	90	90	180	180	180	180	370	550
Solenoid valve -Volt/Watt	24 AC / 6	24 AC / 6	24 AC / 6	24 AC / 6	24 AC / 6	24 AC / 6	24 AC / 6	24 AC / 6
Pneumatic supply - Bar	2 - 8	2 - 8	2 - 8	2 - 8	2 - 8	2 - 8	2 - 8	2 - 8
Construction certificates	CE	CE	CE	CE	CE	CE	CE	CE
Maximum size of inlet particles* - mm	3	3	3	3	3	3	3	3
Max total suspended solids at inlet - 125 micron - mg/l	100	100	100	100	100	100	100	100
A (mm)	757	903	1071	1309	1755	2027	2581	3181
B (mm)	470	485	607	635	706	791	969	969
C (mm)	327	327	423	423	516	714	852	852
D (mm) Cartridge extraction	450	600	640	885	1130	1160	1160	1690
WEIGHT when empty Kg	28	34	51	62	75	115	208	285
WEIGHT in operation Kg	36	45	83	106	133	202	346	598

*upon request 5 and 8 mm

DIMENSIONS AND TECHNICAL DATA SCR O

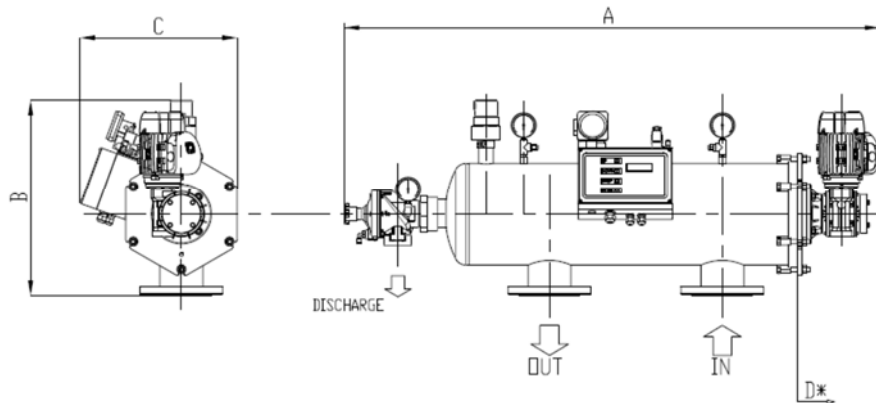

MODEL	SCR O 10	SCR O 15	SCR O 30	SCR O 45	SCR O 60	SCR O 75	SCR O 90	SCR O 130
Filtering area (cm ²)	1000	1500	3000	4500	6000	7500	9000	13000
Connections- In/Out	2"	3"	DN100	DN150	DN200	DN250	DN300	DN350
Exhaust connections	1"1/2 F	1"1/2 F	2" F	2" F	2" F	2" F	2" F	2" F
1 Bar washing flow rate with mesh from 500 to 25 micron - m ³ /h	2	3	7	9	9	9	9	15
Wash duration - Sec.	15	15	15	15	15	15	15	15
Min-max pressure - Bar	0,5-10	0,5-10	0,5-10	0,5-10	0,5-10	0,5-10	0,5-10	0,5-10
Max Temperature - °C	40	40	40	40	40	40	40	40
Power supply - Volt	400 50/60 Hz	400 50/60 Hz	400 50/60 Hz	400 50/60 Hz	400 50/60 Hz	400 50/60 Hz	400 50/60 Hz	400 50/60 Hz
Power required - Watt	90	90	180	180	180	180	370	550
Solenoid valve -Volt/Watt	24 AC / 6	24 AC / 6	24 AC / 6	24 AC / 6	24 AC / 6	24 AC / 6	24 AC / 6	24 AC / 6
Pneumatic supply - Bar	2 - 8	2 - 8	2 - 8	2 - 8	2 - 8	2 - 8	2 - 8	2 - 8
Construction certificates	CE	CE	CE	CE	CE	CE	CE	CE
Maximum size of inlet particles* - mm	3	3	3	3	3	3	3	3
Max total suspended solids at inlet - 125 micron - mg/l	100	100	100	100	100	100	100	100
A (mm)	900	1045	1430	1675	1920	2100	2205	2576
B (mm)	415	415	540	540	540	630	904	1114
C (mm)	330	330	410	410	430	460	634	678
D (mm) Cartridge extraction	450	600	640	885	1130	1160	1160	1690
WEIGHT when empty Kg	30	37	55	67	81	125	220	305
WEIGHT in operation Kg	38	50	91	116	145	222	370	633

These technical data are indicative and subject to changing without notice.
The max suspended solids at inlet is an important factor, because depending on their size distribution and their specific weight they can clog up the filter in a different way.

DESCRIPTION OF PARTS

PART	DESCRIPTION
Body	AISI316 – SAF2205 – SAF2507
Cover	AISI316 – SAF2205 – SAF2507
Connection threading	Cylindrical GAS UNI338-66
Mesh support strainer	PVC
Filtering mesh	Polyester/AISI316 :500,300,200,125,80,50,25 µm
Protection mesh	PE
Suction nozzle	PE
Nozzle support	PVC – AISI316 – SAF2205 – SAF2507
Nozzle pipe	PVC – AISI316 – SAF2205 – SAF2507
Internal seals	EPDM
Reduction unit	Aluminium and carbon steel
Electric motor	Hot-painted aluminium
Solenoid valve	Three-way aluminium
Switchboard	ABS IP55 with front display
Differential pressure switch	Aluminium with parts in contact with liquid made of AISI 316
Discharge valve	PP diaphragm with flow rate regulation
Pressure gauges	Stainless steel with 2"1/2 dial, radial connection and 0-10 Bar indication
Accessories (Plugs and adapters)	PP – PVC – AISI316

FILTERING MESH FLOW RATE TABLE FOR SCR L FILTERS (m³/h)

MODEL	500 µm PES AISI316	300 µm PES AISI316	200 µm PES AISI316	125 µm PES AISI316	80 µm PES AISI316	50 µm PES AISI316	25 µm PES AISI316
SCR 2-10	30	30	30	30	30	26	13
SCR 3-15	50	50	50	50	50	39	19
SCR 100-30	147	147	147	147	111	78	34
SCR 150-45	216	216	216	216	166	117	59
SCR 200-60	373	373	373	315	222	156	78
SCR 250-75	573	573	573	395	277	195	98
SCR 300-90	720	720	720	473	333	234	117
SCR 350-130	1038	1038	1038	682	373	338	169

The flow rates indicated refer to a load loss of 0.2 Bar with clean, filtered water.

SUGGESTED INTALLATION

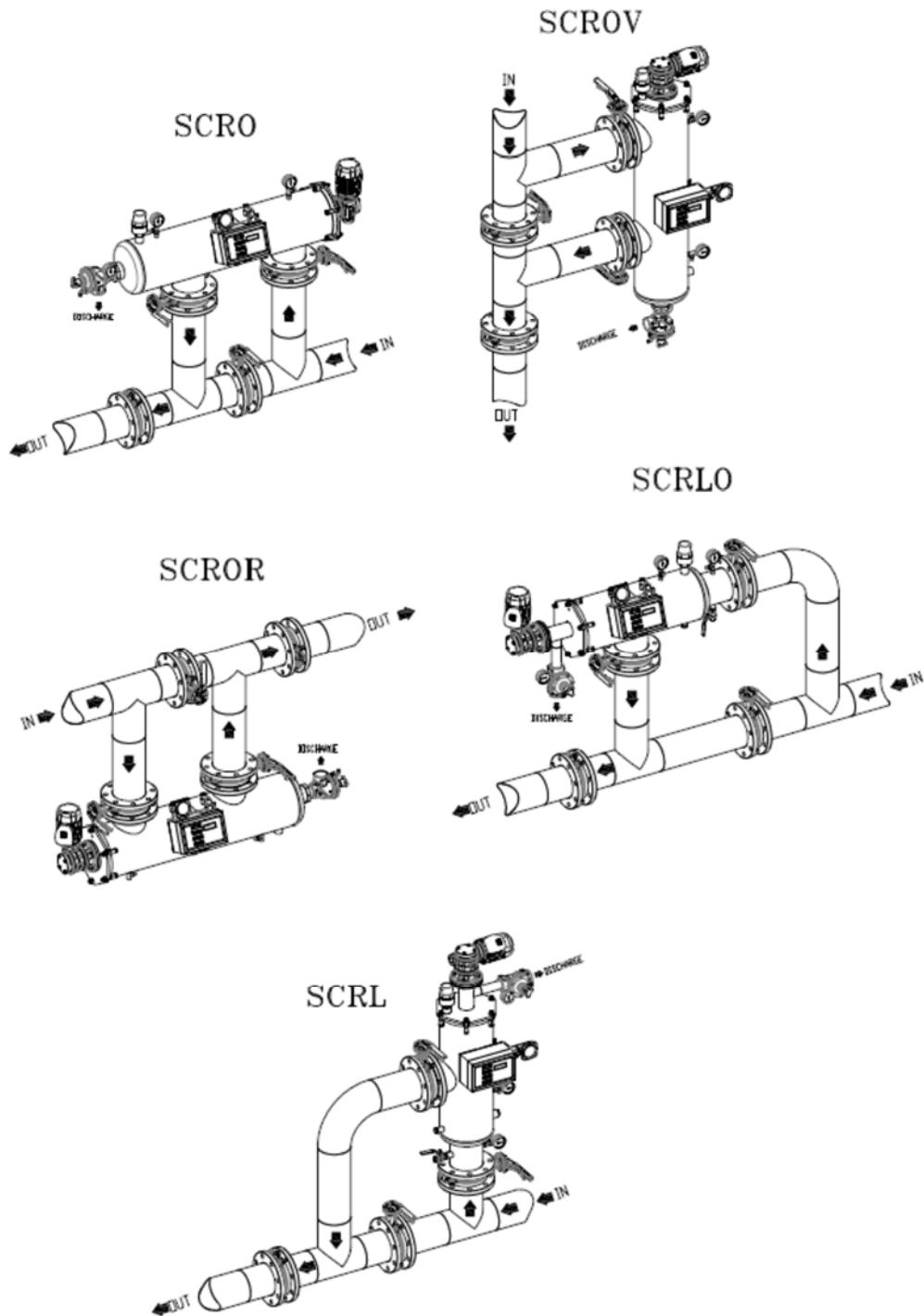

FILTER CODING TABLE

1 SHAPE / INSTALLATION FILTER	CODE
L / VERTICAL	SCRL
L / HORIZONTAL	SCRLO
O / HORIZONTAL	SCRO
O / REVERSE HORIZONTAL	SCROR
O / VERTICAL	SCROV

2 APPLICATION	CODE
INDUSTRIAL	I

3 BODY / COVER MATERIAL	CODE
AISI 316	0316
SAF2205 (DUPLEX)	2205
SAF2507 (SUPERDUPLEX)	2507

4 CONNECTION IN/OUT	CODE
2" BSP	002
3" BSP	003
DN80 PN10	080
DN100 PN10	100
DN150 PN10	150
DN200 PN10	200
DN250 PN10	250
DN300 PN10	300
DN350 PN10	350

5 FILTER ELEMENT SIZE	CODE
10	010
15	015
30	030
45	045
60	060
75	075
90	090
130	130

6 BASKET MATERIAL	CODE
PVC-U	1
AISI316	2

7 FILTERING FABRIC MATERIAL	CODE
POLYESTER	1
AISI316	2

8 NOZZLE SUPPORT MATERIAL	CODE
POM-C (10-15-30-45)	1
AISI316 (60-75-90-130)	2
SAF2205 (DUPLEX)	3
SAF2507 (SUPERDUPLEX)	4

9 NOZZLE PIPE MATERIAL	CODE
PVC-U (10-15-30-45)	1
AISI316 (60-75-90-130)	2
PVC-C	3
SAF2205 (DUPLEX)	4
SAF2507 (SUPERDUPLEX)	5

10 PILOT DISCHARGE VALVE	CODE
PNEUMATIC	1
HYDRAULICS	2

11 FILTRATION DEGREE	CODE
2000	2000
1500	1500
800	0800
500	0500
400	0400
300	0300
200	0200
120	0120
80	0080
50	0050
25	0025

12 AUTOMATION	CODE
CONTROL PANEL + DIFF.SWITCH	C
NONE	0

STANDARD VERSION

ELFI srl

Via Scodoncello 41/E 43044 Collecchio (PR)

ELFI srl

Via Scodoncello 41/E 43044 Collecchio (PR)